



Construction Transport. The Arocs.

Mercedes-Benz
Trucks you can trust



Mercedes-Benz. Trucks you can trust.

From professionals. For professionals. Mercedes-Benz in construction transport.



Mercedes-Benz. This name stands for all the experience of the world's longest established and most highly reputed truck manufacturer and for pioneering vehicle technology.

For all types of construction use and every type of construction site. From rigids through to concrete mixers and tippers – the on-road, off-road and all-wheel drive variants of the Arocs are true specialists of the construction industry. Thanks to their versatility and robustness, they have the right answer for virtually every task and for every segment of the construction industry.

The new Arocs. The new Arocs rated at 18 to 41 t is the specialist for heavy-duty operations. It applies its high power equally reliably and effectively in difficult terrain and on the road. The Arocs additionally is economical to run courtesy of its trusted Euro III engines, the extended service lives of many components, low repair and maintenance costs and high body-mounting ability. In short, Mercedes-Benz delivers what the practical realities require. On the construction site. And on the road. See for yourself.

Index

Reliability	5
Robustness	9
Bodybuilder Friendliness	14



Reliability - more than just a word for us. It stands for a tradition extending back over more than 120 years.

A tradition which gives rise to vehicles you can rely on, as exemplified by the Mercedes-Benz Trucks range. Trucks which have been built to always deliver top performance, even in the most extreme conditions – with the reliability you rightly expect of a Mercedes-Benz.

Trucks you can trust – for more reliability. Reliability. For us, this means providing you with trucks that operate without a hitch, even in extreme conditions and in difficult terrain. In other words: “Trucks you can trust”. As your partner who helps you to master your daily transport tasks efficiently, we will continue to put our all into ensuring you have reliable vehicles at your disposal. With the wealth of experience that comes from more than 120 years in vehicle manufacturing. With trucks boasting robust components that have been tried and tested thousands of times and equipment designed to cope with the topographic and climatic conditions that prevail where the vehicles are to be operated. This applies to engines, gearshifts, transmissions and drive axles as well as frames, chassis, suspension and cabs, as a reliable truck can only ever be the sum of its reliable individual components. Tailored perfectly to practical requirements.

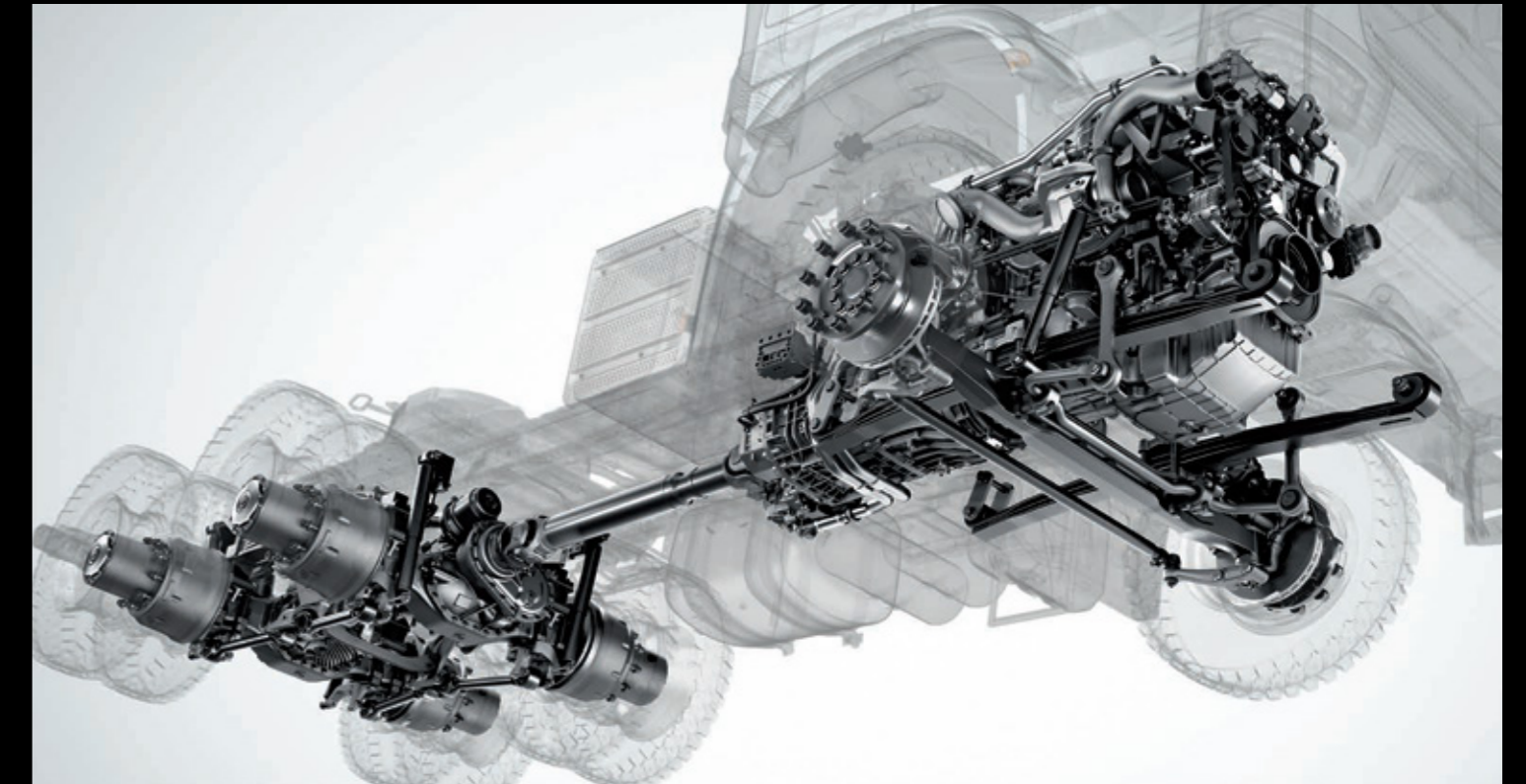

Powertrain. In order to meet all the given high requirements regarding durability and reliability, all components of the powertrain on Mercedes-Benz Trucks are ideally matched – and produced exclusively by Mercedes-Benz.

There's no substitute for reliability.

A truck only earns money when it is up and running. As such, the prime requirement in the ever tougher transport business is for trucks that can be counted on to operate reliably. With particularly durable drive components, the new Mercedes-Benz Trucks range is a shining example of how this is done.

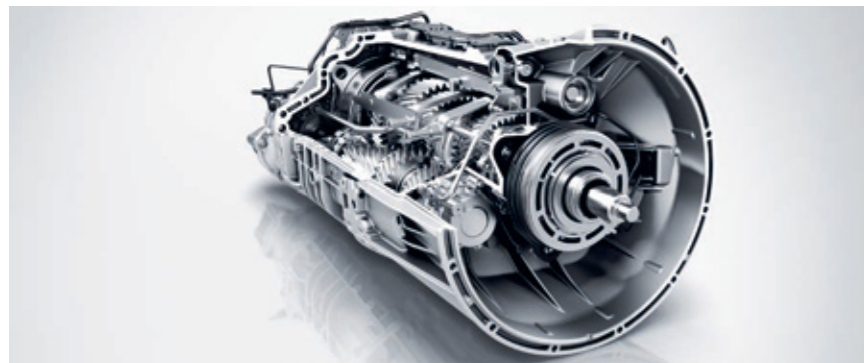

Transmissions for every application. The transmission performs fast gear changing. The generous installation space means that it is also possible to use wide gearwheels. This enables high levels of torque to be transferred.

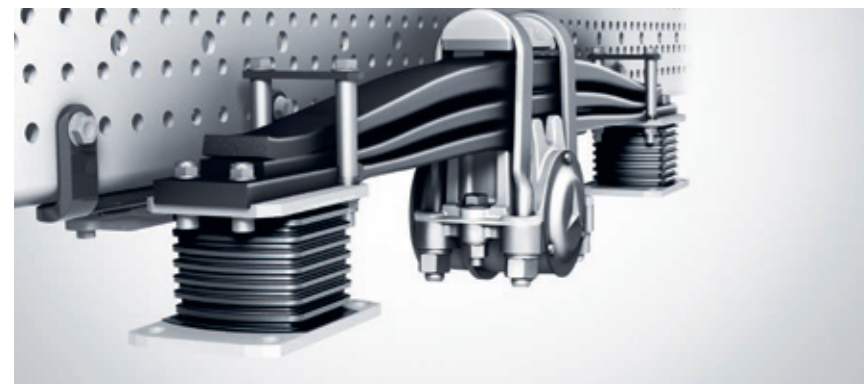

Steel suspension. The steel suspension on the Arocs performs well in every situation by virtue of its robust, solid structure, high resilience and high load capacity.

Reliable engines. The OM460 engine has been developed on the basis of tried and tested technology and robust components. The new inline 12.8-litre 6-cylinder engine configuration with exhaust gas turbocharger and unit pump line injectors obtains a high torque already at low engine speeds and across a wider engine speed range contributing to much improved driving characteristics and a significant increase in economic fuel efficiency.

Mercedes PowerShift3. Superior dynamic response, simple handling and low fuel consumption. The automated transmission ensures precise gear selection, short shift times, high driving comfort and a very high level of economic efficiency. The Mercedes PowerShift 3 applies sensitive sensor technology for gearshifting to ensure gear selection in accordance with the given driving and load situation. Overrun mode on a downhill gradient is identified and the gear is held. The crawl function with integral manoeuvring mode makes moving off easy and manoeuvring precise and responsive. Furthermore, there are various transmission modes and additional functions to make driving in construction transport easier.

Suspension variants. Suspension variants. Robust steel suspension or a combination of steel suspension and air suspension – the Arocs has the right solution according to the intended application. A robust, durable steel suspension provides good load capacity and high suspension comfort in construction site use. With the weight-optimised parabolic spring assemblies and corresponding precisely matched shock absorbers and stabilisers, you are all set for whatever your operations hold in store.

Axles. On-road, off-road or at the construction site – the axles on the Arocs are impressive performers in every type of operation. The planetary axle with a load capacity of up to 16 t comes into its own at the construction site and for heavy haulage. Depending on the type of application and chassis, various front axles with a permissible front axle load of up to 9 t are available. The particularly robust planetary axles also offer high ground clearance. This is possible because the main transmission operations take place in the outer planetary gearing, as a result of which the crown wheel and pinion require less space. For road use, the Arocs is fitted with hypoid drive axles with a load capacity of up to 13 t.

Brakes. Depending on the type of deployment, for a high standard of safety we equip the trucks either with disc brakes or drum brakes. The high power of the engine brake and retarder boost the available braking power, reduce wear and improve economic efficiency.

All-wheel-drive range. Two all wheel-drive variants are available for outstanding traction: permanent all-wheel drive with low-range gear and disengageable all-wheel drive. For the

majority of its work which entails demanding manoeuvres in difficult terrain, such as moving off on gradients on unsurfaced terrain, the Arocs is equipped with permanent all-wheel drive.

Extensive testing. All Arocs components are engineered to be particularly durable, repair- and maintenance-friendly and boast a high degree of reliability. This is further ensured by extensive testing at the Mercedes-Benz Development and Testing Centre in Wörth, where worldwide road conditions are

simulated, enabling our trucks to be tested under the toughest conditions. The unrelenting test programme also includes summer and winter trials at extreme temperatures and millions of kilometres on rough road tracks and in endurance testing. Overall, the new Mercedes-Benz Trucks range has demonstrated its durability and reliability over more than 60 million test kilometres.



High-quality production. With more than 120 years of experience in truck production, premium Mercedes-Benz quality is assured at every step of the production process to guarantee maximum reliability.

Advantages at a glance.

- 6-Cylinder in-line engines which are particularly reliable, efficient and durable
- Mercedes PowerShift3 for easy operation, reduced shift times, precise gear selection and fuel savings
- Efficient hypoid axles and robust planetary axles for high axle loads
- Extensive testing and high-quality production process guarantees that every truck earns its star
- Increased cooling capacity for engine and transmission



Robustness - Rough work calls for a robust vehicle.

Regardless of whether it is a semitrailer tractor vehicle, platform vehicle, cement mixer or heavy-duty tipper: The on-road and all-wheel variants of the Arocs provide an especially robust, resilient vehicle that is optimally prepared for use for almost any construction haulage challenge.

Robustness. The robustness and load-bearing capacity of the Arocs are fully reflected in the application specific cabs – from the durable, extremely tough cab shell to the athletic and powerful design. A high standard of driving comfort and ergonomics is provided by comfortable cockpit with multifunction steering wheel, the Mercedes PowerShift 3 automatic gearshift and a broad range of wide and comfortable seats. Unique connectivity and equipment such as the new the electronic parking brake further enhance driving comfort and ergonomics.

Power. The Arocs takes virtually any driving situation in its stride. The robust, reliable OM460 engines, transmission and axles are manufactured exclusively by Mercedes-Benz and designed specifically for the special requirements of construction transport at gross weights of 18 tonnes and over. The unique suspension and frame designs, the intelligent control of the drive components, the high torque of the engines and the extremely fast shift times of Mercedes PowerShift 3 ensure that ample power is available.

For the best possible traction and good steerability the drive system, chassis, suspension and frame form a precisely coordinated working team which is optimally configured in all Arocs vehicles for the particular application in question on the road, on the construction site or on extreme terrain. To easily take on terrain with large approach and departure angles, we have additionally provided the Arocs with optimised ground clearance. As you can see, the Arocs is up to any challenge. Climb aboard!



For extreme operations. Thanks to a host of technical measures, the Arocs is even more robust and possesses a particularly high degree of stability and load-bearing capacity. The economical option. From day one.

Solid vehicle construction: The new Arocs with newly and specifically developed robust design.

The construction site is its playground: the Arocs rated at 18–41 tonnes.

Robust in every detail. One look is all it takes to know where the Arocs belongs. From the flexible entry pivoting in both longitudinal and lateral directions to the rugged interior – every detail is designed precisely for the requirements of a construction site. This means: maximum functionality in tandem with impressive robustness. Clearly evident in the rippled exterior mirror housings and the radiator grille with bucket-tooth design. Clearly tangible in the comfort cab suspension, which eases the load on the driver even under great strain in terrain. Plus the three-piece bumper with steel corners. The steel corners protect the headlamps from damage.

Special cab design. The Arocs always puts a cab that is optimally designed for the requirements of construction transport at your disposal. The cabs with a width of 2300 mm offer great all-round visibility, for example – this provides protection against collisions if space for manoeuvring is especially tight. The construction from 100% fully galvanised sheet metal is another persuasive trait of the Arocs cabs.



Protective headlamp grille. Robust protective steel grilles are available for the headlamps and tail lamps of the Arocs. They can prevent damage as caused by stone chips, for example. This contributes to low repair costs and enhanced safety.



Protective plate for engine and radiator. Many off-road models come with a steel plate to protect the radiator and the engine.



The best seat is reserved for the driver.

During the first test drive and after countless trips – the Arocs cabs show what distinguishes a modern workplace. With exemplary ergonomics, high functionality and lots of new and practical details that simply make a difficult job much easier.

Cockpits feature a practical and comfortable driver's workplace which also serves as an information and command centre at the same time. The main vehicle functions can be controlled conveniently and safely using the multifunction steering wheel. The automated gearshift is operated by means of the right-hand steering-column lever. Similarly, all the other control switches, the radio, as well as the handy stowage facilities are positioned ergonomically within the driver's reach. In short, it is the ideal environment for focused working, relaxed driving and precise operation.



Ergonomic workplace. The Arocs offers a workplace which is ideally designed for construction transport operations. The cockpit with its appealing interior is tailored precisely to the driver's needs. The cockpit imparts a pleasant feeling of space and features ergonomically arranged controls and stowage facilities. The Mercedes PowerShift3 automated gearshift is conveniently operated using the steeringcolumn lever.



Engine start/stop button. Keyless Start. The new vehicle key not only looks good, but is conducive to simpler handling. In order to start the engine it is sufficient for the key to be in the vehicle, which means it can remain in the driver's jacket or trouser pocket while on the move.



Bodybuilder Friendliness - Modular Layout of the Chassis.

The modular Layout of the chassis allows for easier body mounting. Mounting elements are systematically oriented towards the respective add-on equipment, the chassis of the new Arocs has a consistent hole pattern of 50 mm with easy access to electrical and pneumatic attachments. The right frame for every application. Construction-site and on-road use impose different requirements on the frame. That is why we have developed two for the Arocs. One with a narrow frame track of 744 mm, which boasts high torsional flexibility and stability even under extreme off-road conditions and one with a wide 834 mm frame track, which comes into its own in on-road use while also performing convincingly in light off-road use.



The Application Specific mounting elements provide for a Bodybuilder Friendly and fast mounting process. For all Freight Carriers the Mounting parts - Platform (C5I) are standard. The new generation Parameterisable Special Module (PSM) also aids in significantly reducing turnaround time at the bodybuilder.



Mounting parts - Mixer (C5K) - Standard on all mixer chassis.



Mounting parts - Tipper (C5J) - Standard on all tipper chassis



Please note: changes may have been made to the product since this manual went to press (01.10.2021). The manufacturer reserves the right to make changes to the design, form, colour and specification during the delivery period, provided these changes, while taking into account the interests of the vendor, can be deemed reasonable with respect to the purchaser. Where the vendor or the manufacturer uses symbols or numbers to describe an order or the subject of an order, no rights may be derived solely from these. The illustrations may show accessories and items of special equipment which are not part of standard specification. Colours may differ slightly from those shown in the brochure, owing to the limitations of the printing process. This manual may also contain models and services which are not available in certain

countries. This manual is distributed internationally. It provides a general indication of the range of models, features, special equipment and/or colours available in various countries. Some of the models, features, special equipment and/or colours may not be available in your country, or may only be available in a different specification. Additionally some models, features, special equipment and/or colours may only be available in combination with others. For current and more specific information relating to the range of models, features, special equipment and/or colours available in your country, and their pricing, you should contact your nearest Mercedes-Benz Truck Dealer.

Daimler Trucks & Buses Southern Africa (Pty) Ltd.

Printed in South Africa